

PARTS LIST			
ITEM	QTY	PART NUMBER	MATERIAL
1	1	DRILL PRESS	CAST IRON

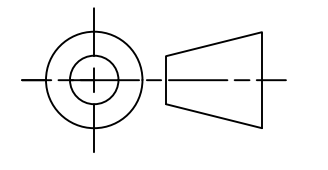
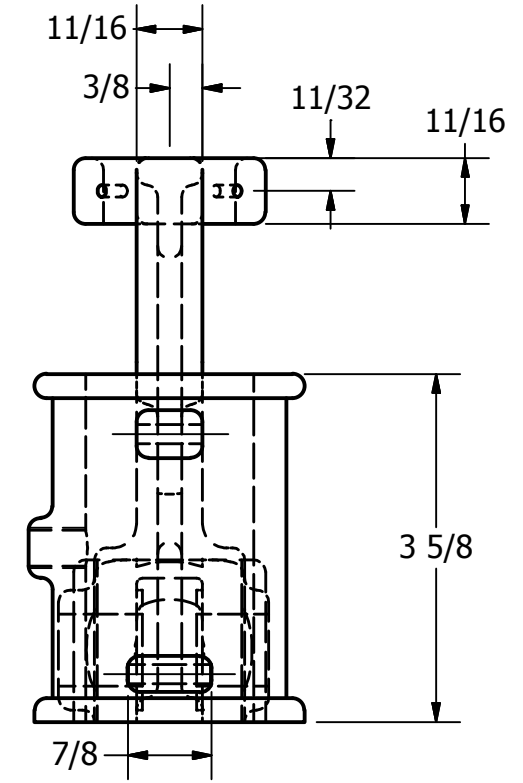
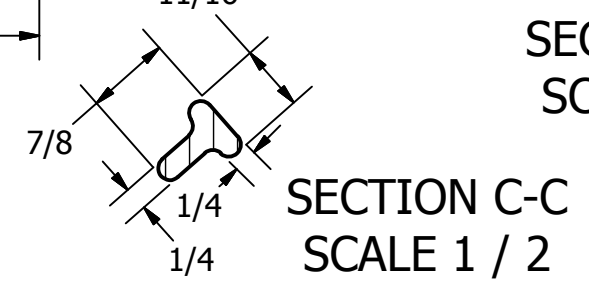
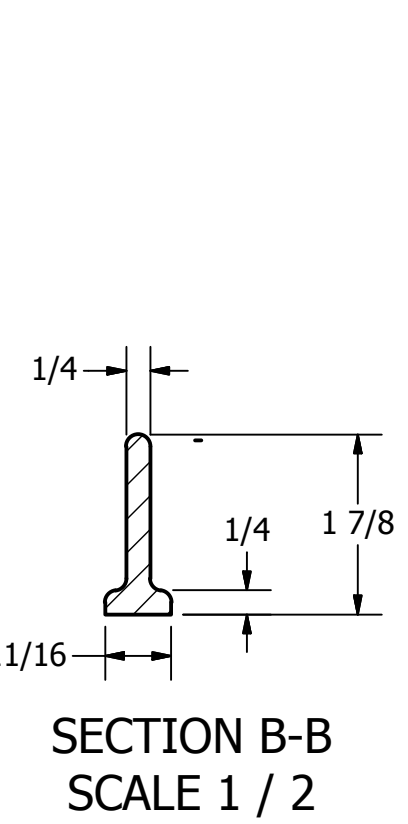
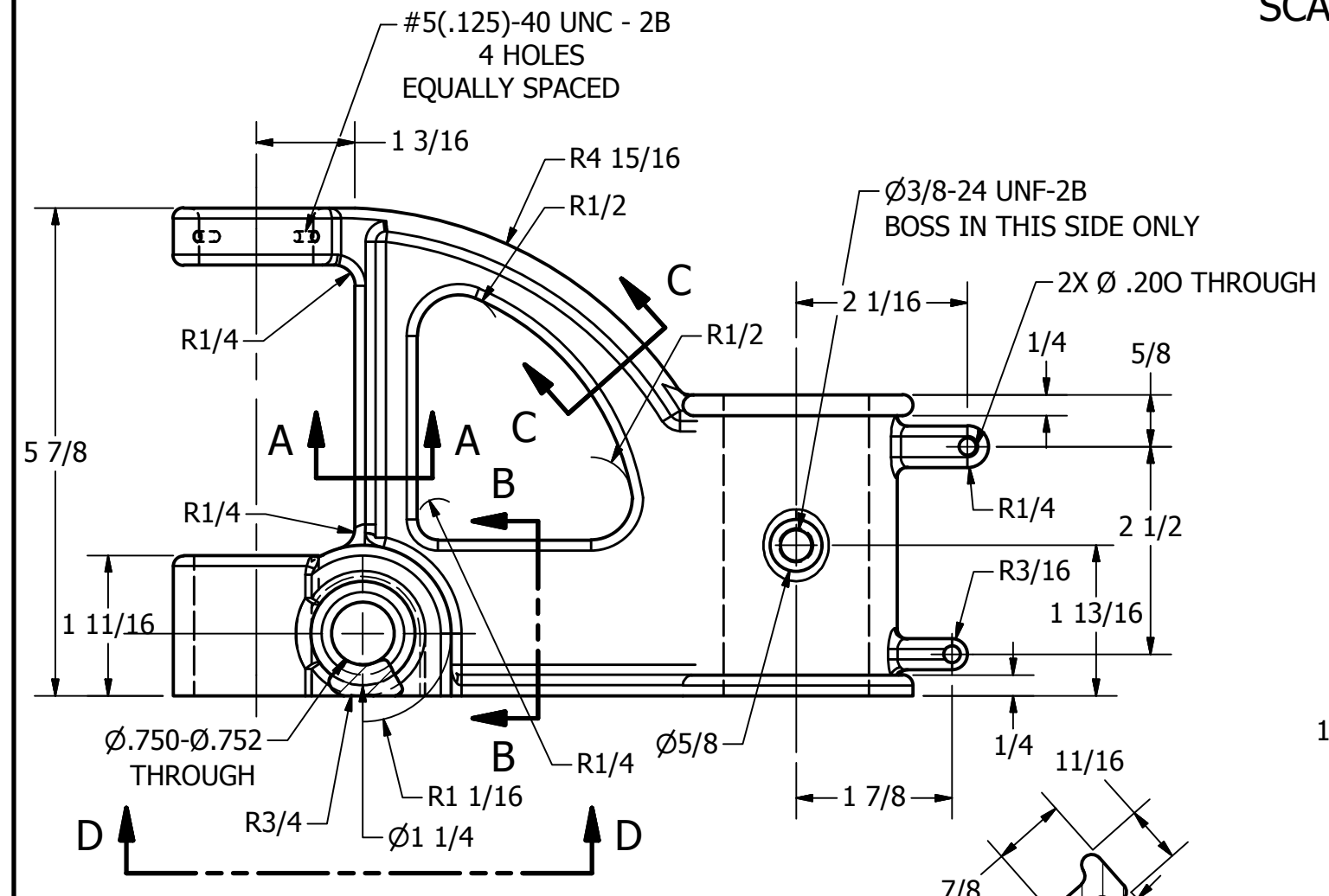
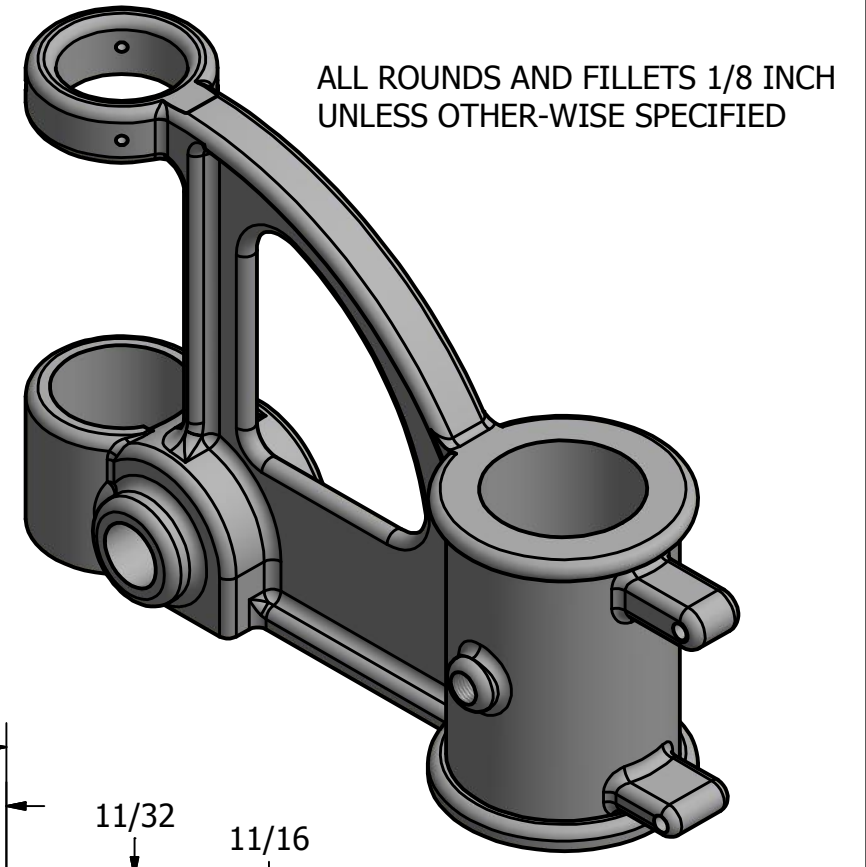
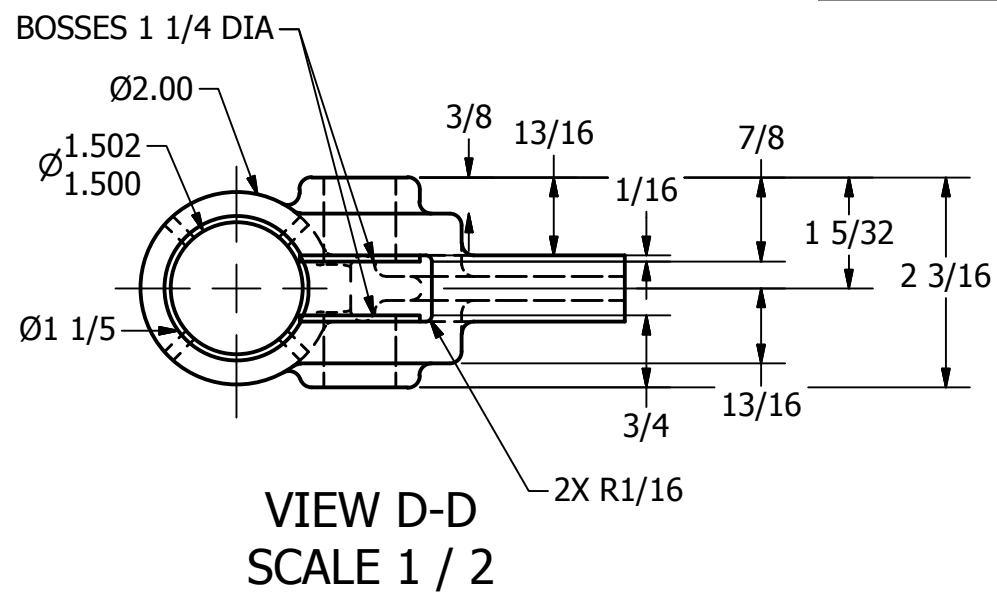
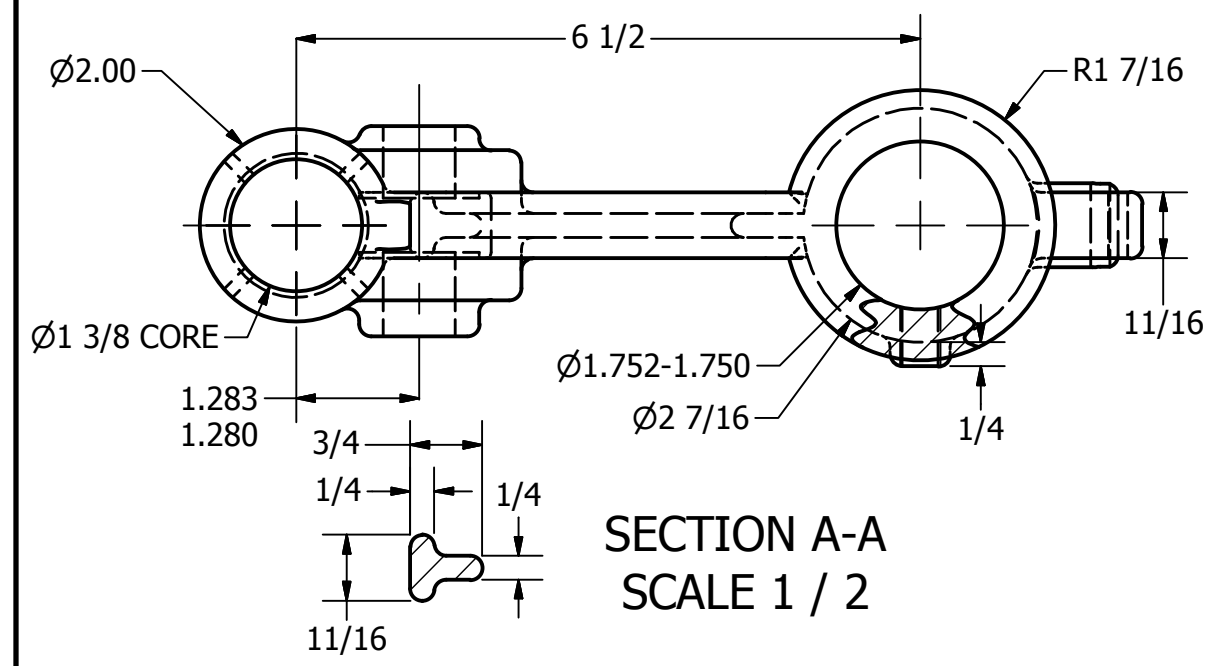

LEGEND
 Ø - DIAMETER
 ° - DEGREES
 R - RADIUS

DRILL PRESS BRACKET
 SCALE 1 / 2

SECTION C-C
 SCALE 1 / 2

SECTION B-B
 SCALE 1 / 2

DIGITAL DESIGN GRAPHICS TECHNOLOGY	NAME:	E.PEREZ	DWG NAME:	14-35	SHEET NO:	1 OF 1
	COURSE:	DDGT 121		DRILL PRESS BRACKET		
	DATE:	4/18/2013	SCALE:	1:2		

PRODUCED BY AN AUTODESK EDUCATIONAL PRODUCT

PRODUCED BY AN AUTODESK EDUCATIONAL PRODUCT